

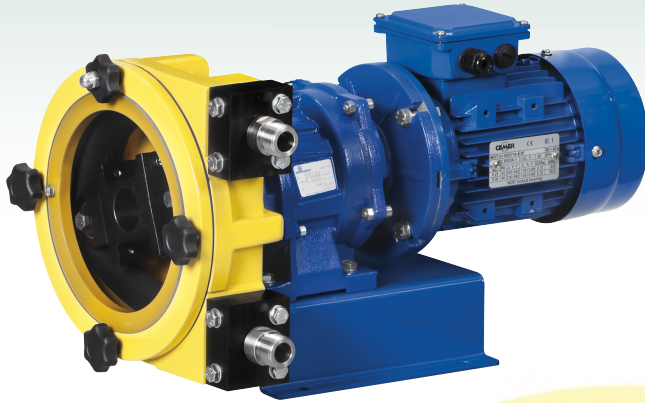

# Industrial Peristaltic Pumps

## AMP-10B Data sheet



<b>Capacity:</b>	0,023 l/rev.
<b>Connections:</b>	3/8"
<b>Max. Pressure:</b>	8 bar
<b>Rotor system:</b>	Rollers
<b>Available hoses:</b>	NR NBR EPDM HYPALON NR-A NBR-A
<b>Available tubes:</b>	TPV

Performance table

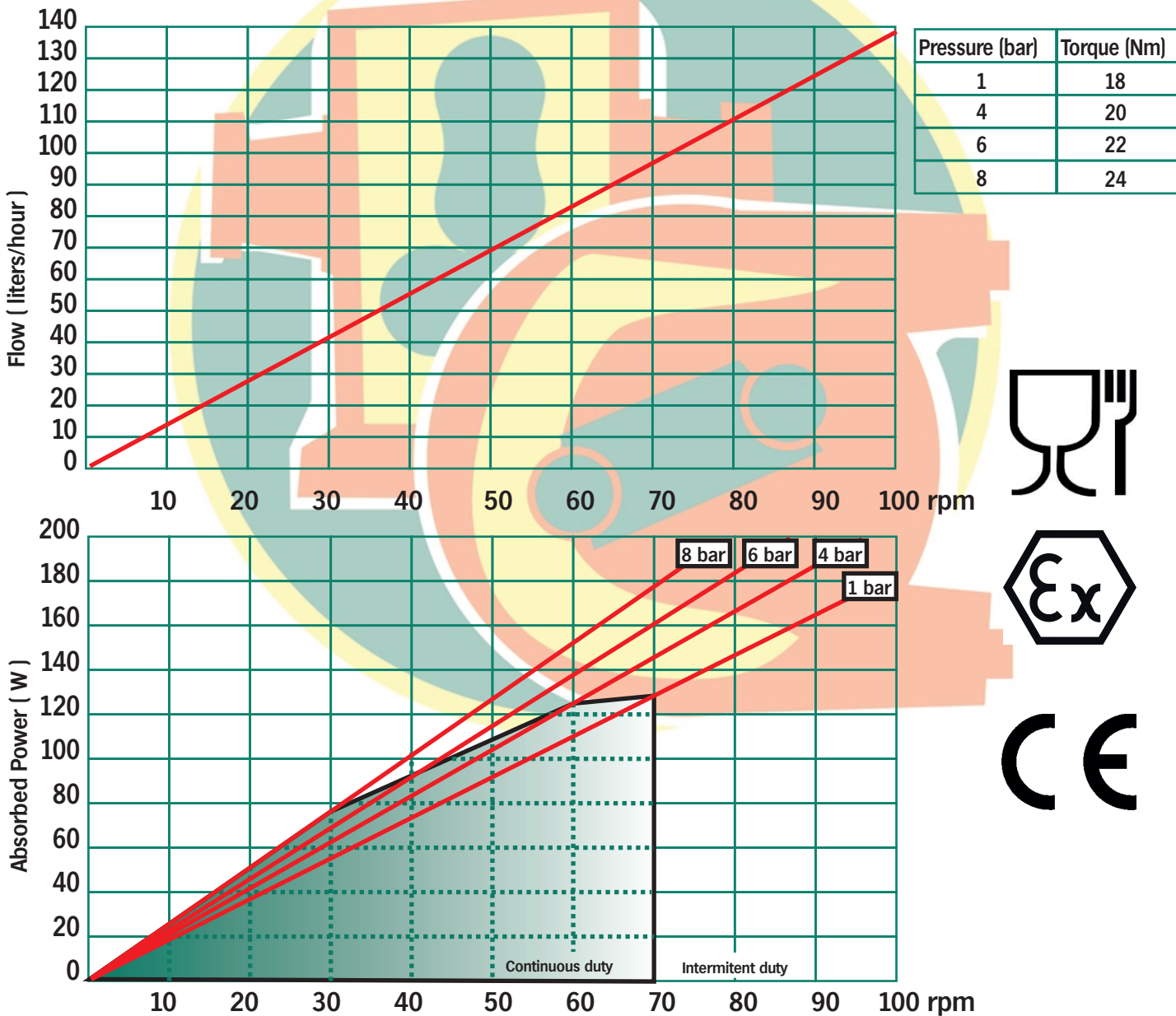

Description	Material	Surface treatment
Pump housing	Alluminium EN-AC-44100	Polyester powder coated Halar coated (Optional)
Front cover	Methacrylate	--
Rotor	Nodular Cast Iron EN-GJL-400	Cataphoresis
Rollers	Steel F-114	Blueing
Base plate	Steel F-111 Stainless Steel AISI-304 (Optional)	Polyester powder coated --
Connections	Stainless Steel AISI-304 Polypropylene (Optional) PVDF (Optional)	--

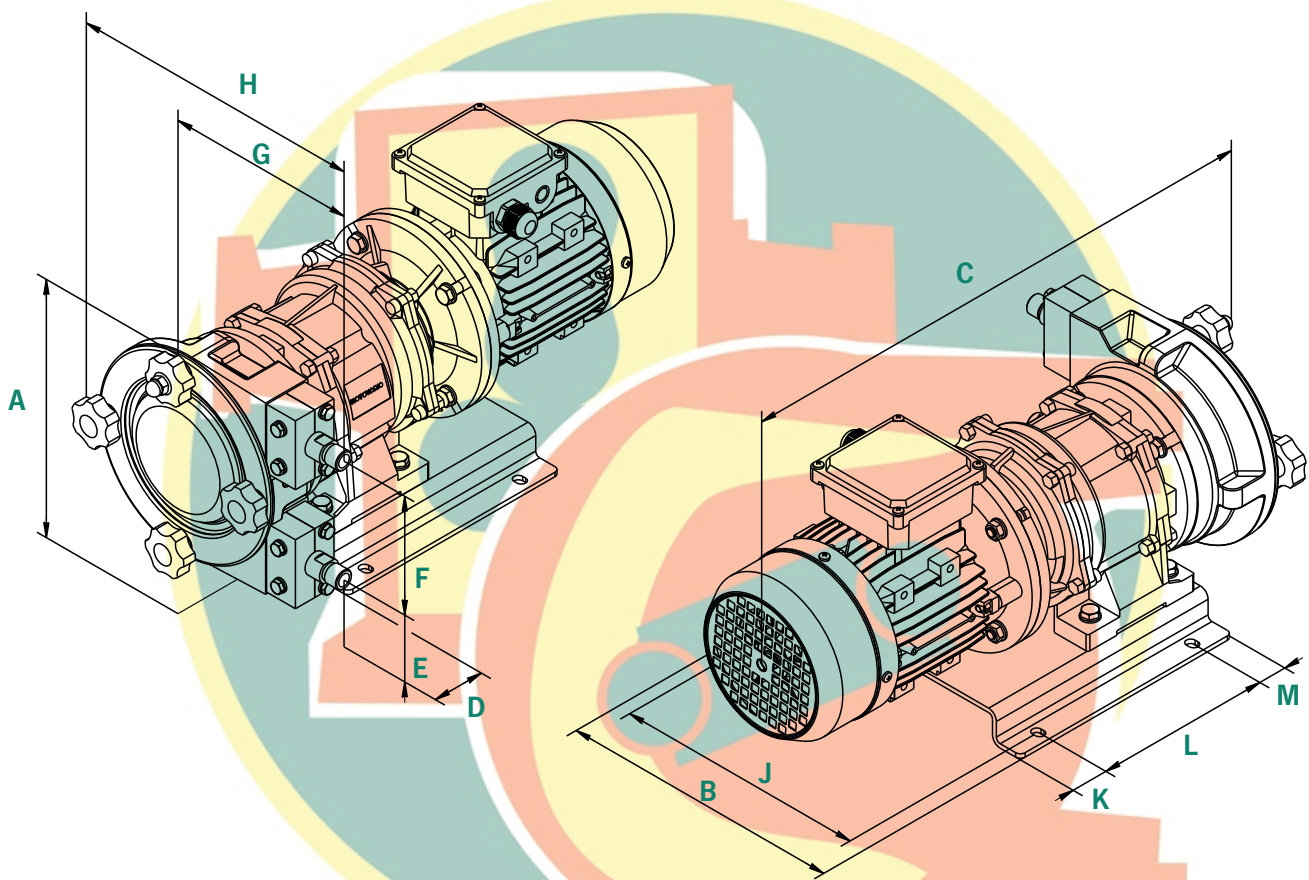

A	B	C	D	E	F	G	H	J	K	L	M	Connections
202	210	*	39	52	107	141	238	187	30	160	30	3/8" BSP

\* To confirm according type and power driver.



**Bombas Boyser, S.L**  
 c/ Miquel Martí i Pol, s/n Pol. Ind. Pla de la Costa  
 08182 Sant Feliu de Codines - Barcelona - Spain  
 Tel. +34 93 844 77 78 info@boyser.com

[www.boyser.com](http://www.boyser.com)

